

POWER RATING

Production tolerance : ± 3%

MODEL	CONDITIONS	POWER	rpm	Base Engine
MD196T	HEAVY DUTY	280PS (206kW)	2,000	DE12T

Note : 1) No reduction in rating for intake air temperature is up to 45 °C (318K) and sea water temperature is up to 32 °C (305K) , relative humidity is up to 60 % all data are based on operation to ISO 3046.

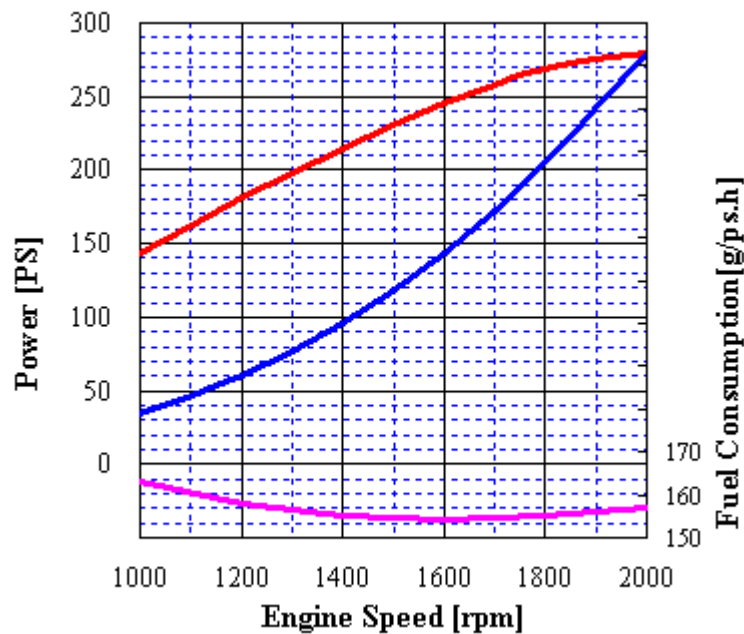
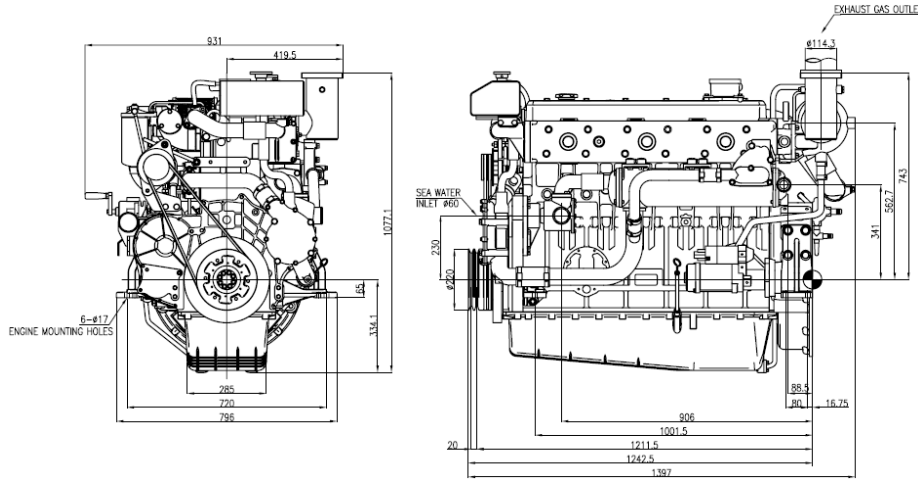

- **Heavy Duty** : Operation hours are unlimited per year, at average load is up to 90 % ,
 At full load is up to 80 %
 Typical gearbox ratio: 2.5 ~ 6
 (Fishing trawler, Tug boat, Pushing vessel, Cargo boat, Freighter, Ferry)

Engine Specification			
Model	Units	MD196T	
Engine type		4 cycle, In line, direct- injection, water cooled with wet turbo charger	
Rating output (B.H.P)	PS(kW)/rpm	280(206)/2,000	
Displacement	cc	11,051	
Cylinder number - bore(ϕ) x stroke	mm	6 - ϕ 123 x 155	
Valve clearance at cold	In / Ex	mm	0.3 / 0.3
Low idling rpm	rpm	725 \pm 25	
No load max. rpm	rpm	below 2,200	
Mean effective pressure	kg/cm ²	11.41	
Mean piston speed	m/sec.	10.33	
Compression ratio		17.1 : 1	
Firing order		1 - 5 - 3 - 6 - 2 - 4	
Max. firing pressure of cylinder	kg/cm ²	106	
Compression pressure	at 200 rpm	kg/cm ²	28 (Initial condition)
Governor type of injection pump		Mechanical variable speed (R.Q.V)	
Fuel consumption		g/PS.h	156
		lit / h	49
Injection timing (B.T.D.C)		deg	14 ^o \pm 1 ^o
Fuel inj. nozzle opening pressure		kg/cm ²	1st : 160 , 2nd : 220
Starting system		Electric Starting by starter motor	
Starter motor capacity		V- kW	24 - 6.0
Alternator capacity		V- A	24 - 50
Battery		V- Ah	24 - 150
Cooling system		Indirect sea water cooling with heat exchanger	
Cooling water capacity	Max. / Min.	lit	24 / 19
Fresh water pump type		Centrifugal type, driven by gear	
Sea water pump type		Rubber impeller type driven by gear	
Lubricating oil (Engine)	Pan capacity	lit	Max : 25, Min : 19 (Engine total : 27)
	Pressure	kg/cm ²	Full : 3.5, Idle : 1.2
Marine gear	Model		DMT136H (Dong-I)
	Gear ratio		1.97 2.57 3.08 3.46
Direction of revolution	Crankshaft		Counter clockwise viewed from stern side
	Propeller		Clockwise viewed from stern side
Engine size (L x W x H)	Without M/G	mm	1,397 x 931 x 1,077
	With M. gear	mm	1,662 x 931 x 1,129
Engine dry weight	Without M/G	kg	975
	with M. gear	kg	1,225

psi = kg/cm² x 14.22
 lb/ft. = N.m x 0.737
 kW = 0.2388 kcal/s

lb= kg x 2.205
 lb/PS.h = g/kW.h x 0.00162
 cfm = m³/min x 35.3

hp = PS x 0.98635
 U.S gal. = liter x 0.264

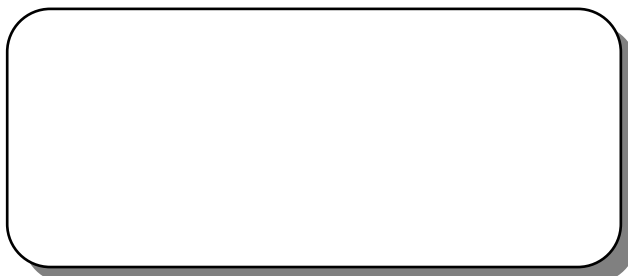

Head office
 7-11, Hwasu-Dong, Dong-Gu, Incheon, Korea
TEL : 82-32-211-2246, 2248 FAX : 82-32-761-2759
Seoul Office
 Doosan Infracore Co. Ltd.,
 21st Floor, Doosan Tower, 18-12, Euljiro 6-ga, Jung-gu,
 Seoul, Korea.
TEL : 82-2-3398-8400 FAX : 82-2-3398-8509
Web site : www.doosaninfracore.com

※ Specifications are subject to change without prior notice.